

■ StandMaster I



▲ High quality, portable projector table for professional projection presentations at any desired location.

Features

Reliable and solid projector table in streamlined design.

Well designed and easy to operate.

Easy, continuous height adjustment with built-in pneumatic spring.

With two fold-away shelves for projector and notebook.

Rotating and continuous height adjustable lower shelf for notebook.

Large wheels provide easy mobility.

Also suitable as caddy for transport of notebook/projector.

Technical characteristics

- ▶ Sturdy steel frame powder coated in dark grey (RAL 7021).
- ▶ Stylish easy-to-clean shelves in light grey (RAL 7035).
- ▶ Large wheels Ø12,5 cm.
- ▶ Easy to assemble.

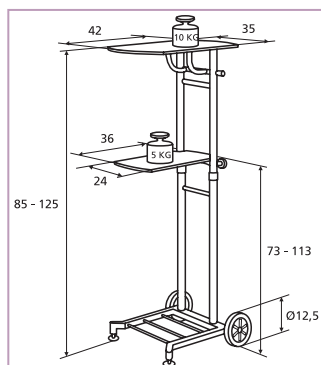

Type	Dark grey frame prod. code	Net weight in kg
StandMaster IA	11200040	13

■ StandMaster II



▲ Solid portable projector table suitable for large projectors.

Features

Robust stable projector table for large projectors (max. 25 kg).

Well designed and easy to operate.

Continuous height adjustment with crank mechanism.

Large upper shelf inclinable to 15°.

Large, removable and transferable lower shelf for notebook or dvd/video equipment.

Large wheels in front and casters behind provide easy mobility.

Technical characteristics

- ▶ Sturdy steel frame powder coated in dark grey (RAL 7021).
- ▶ Stylish, easy-to-clean shelves in light grey (RAL 7035).
- ▶ Extra large wheels Ø16,5 cm.
- ▶ Easy to assemble.

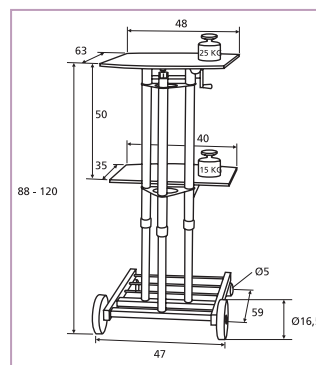

Type	Dark grey frame prod. code	Net weight in kg
StandMaster IIA	11200042	23